

SPECIFICATIONS	Model	B-series							
	100B43.7	3.7kW, 3-phase							
<p><b>Type of Pump</b> Submersible cast iron pump suitable for pumping sewage, wastewater, storm water, etc.</p> <p><b>Type of Fluid</b> Sewage, wastewater, and water carrying solid matters</p> <p>Temperature: 0 to 40°C (High temperature model available on special request)</p> <p><b>Discharge Bore</b> 100mm</p> <p><b>Motor Output</b> 3.7kW</p> <p><b>Power Supply</b> Three-phase</p> <p><b>Starting Method</b> Direct on Line (Star-Delta available on special request)</p> <p><b>Motor</b> Continuous-duty rated, dry-type induction motor</p> <p>Insulation Class: E (available in F on special request) Degree of Protection: IP68</p> <p>No. of Poles &amp; Speed (Synchronous Speed) 4-pole, 1500/1800min<sup>-1</sup> (50/60Hz)</p> <p>Power Supply Voltages &amp; Rated Currents</p> <table border="0"> <tr> <td>50Hz</td> <td>60Hz</td> </tr> <tr> <td>380V – 8.2A</td> <td>220V – 14.2A</td> </tr> <tr> <td>400V – 7.9A</td> <td>380V – 8.0A</td> </tr> <tr> <td>415V – 7.7A</td> <td>440V – 7.1A</td> </tr> </table> <p><b>Power Cable</b> Sheath: PVC Standard Length: 6m 380 to 600V supply: 1 × 4 × 2.0mm<sup>2</sup>, O.D. 11.8mm 200 to 240V supply: 1 × 4 × 3.5mm<sup>2</sup>, O.D. 13.9mm</p> <p><b>Dry Weight (excluding cable)</b> Free Standing Type: 84kg Guide Rail Fitting Type: 80kg</p>	50Hz	60Hz	380V – 8.2A	220V – 14.2A	400V – 7.9A	380V – 8.0A	415V – 7.7A	440V – 7.1A	<p><b>Impeller</b> Semi-open single-channel impeller for solid-handling design, dynamically balanced</p> <p>Solids Passage 50Hz – 81 × 53mm 60Hz – 81 × 47mm</p> <p><b>Cable Entry with Anti-Wicking Block</b> Watertight cable entry with strain-relief device. The anti-wicking block prevents water incursion due to capillary action should the power cable be damaged or the end submerged.</p> <p><b>Bearings</b> Permanently lubricated, deep-groove, double-shielded C3 ball bearings</p> <p><b>Shaft</b> 420 stainless steel</p> <p><b>Shaft Seal (Mechanical Seal)</b> Furnished with a double-face mechanical seal located in oil chamber. Both upper and lower seal faces always run in a clean environment.</p> <p>Upper Seal Faces: Ceramic + Carbon Lower Seal Faces: SiC + SiC</p> <p><b>Oil Seal (Lip Seal)</b> Used as a “Dust Seal”, it protects the mechanical seal from abrasive particles.</p> <p><b>OIL LIFTER (Patented)</b> Equipped in oil chamber. It forcibly supplies lubricating oil to the mechanical seal and continues to supply the oil to the upper seal faces even if lubricant falls below the rated volume.</p> <p>Type of Lubricating Oil &amp; Volume Turbine Oil (ISO VG32), 1350ml</p> <p><b>Motor Protection Device</b> A circle thermal protector built in the motor housing. Directly cuts the motor circuit if excessive heat builds up or an overcurrent condition occurs in the motor.</p>
50Hz	60Hz								
380V – 8.2A	220V – 14.2A								
400V – 7.9A	380V – 8.0A								
415V – 7.7A	440V – 7.1A								
<p><b>Optional Accessories</b></p> <table border="0"> <tr> <td data-bbox="177 1789 564 1877"> <p><b>Bend Set (Free Standing Type)</b></p> <ul style="list-style-type: none"> <li>• Discharge Bend</li> <li>• JIS 10kg/cm<sup>2</sup> Screwed Flange</li> </ul> </td> <td data-bbox="879 1789 1209 1821"> <p><b>External Leakage Sensor</b></p> </td> </tr> <tr> <td colspan="2" data-bbox="177 1901 715 2074"> <p><b>TOS/TS Set (Guide Rail Fitting Type)</b></p> <ul style="list-style-type: none"> <li>• Duckfoot Bend</li> <li>• Guide Support</li> <li>• Guide Hook</li> <li>• Lifting Chain 5m (with Shackles)</li> <li>• JIS 10kg/cm<sup>2</sup> Screwed Flange (TOS Set only)</li> </ul> </td> </tr> </table>			<p><b>Bend Set (Free Standing Type)</b></p> <ul style="list-style-type: none"> <li>• Discharge Bend</li> <li>• JIS 10kg/cm<sup>2</sup> Screwed Flange</li> </ul>	<p><b>External Leakage Sensor</b></p>	<p><b>TOS/TS Set (Guide Rail Fitting Type)</b></p> <ul style="list-style-type: none"> <li>• Duckfoot Bend</li> <li>• Guide Support</li> <li>• Guide Hook</li> <li>• Lifting Chain 5m (with Shackles)</li> <li>• JIS 10kg/cm<sup>2</sup> Screwed Flange (TOS Set only)</li> </ul>				
<p><b>Bend Set (Free Standing Type)</b></p> <ul style="list-style-type: none"> <li>• Discharge Bend</li> <li>• JIS 10kg/cm<sup>2</sup> Screwed Flange</li> </ul>	<p><b>External Leakage Sensor</b></p>								
<p><b>TOS/TS Set (Guide Rail Fitting Type)</b></p> <ul style="list-style-type: none"> <li>• Duckfoot Bend</li> <li>• Guide Support</li> <li>• Guide Hook</li> <li>• Lifting Chain 5m (with Shackles)</li> <li>• JIS 10kg/cm<sup>2</sup> Screwed Flange (TOS Set only)</li> </ul>									
TSURUMI MANUFACTURING CO., LTD.									

NO. A-07522-1

# PUMP PERFORMANCE CURVES

TYPE Sewage Submersible Channel Impeller Pump	MODEL (TOS) 100BA43.7-51 (TOS) 100BW43.7-51	FREQUENCY 50 Hz
--	--	--------------------

CUSTOMER'S NAME \_\_\_\_\_

EQUIPMENT TITLE \_\_\_\_\_ NO. \_\_\_\_\_

	STANDARD SPECIFICATIONS	REQUIRED SPECIFICATIONS
DISCHARGE BORE	100 mm	mm
TOTAL HEAD	11 m	m
CAPACITY	1.0 m <sup>3</sup> /min	m <sup>3</sup> /min
MOTOR OUTPUT	3.7 kW	kW
PHASE x VOLTAGE	3 $\phi$ x V	$\phi$ x V
CURRENT	A	A
POLES / REVOLUTION	4 P / S. S. 1500 min <sup>-1</sup>	P / min <sup>-1</sup>
STARTING METHOD	DIRECT ON LINE	
INSULATION CLASS	E	

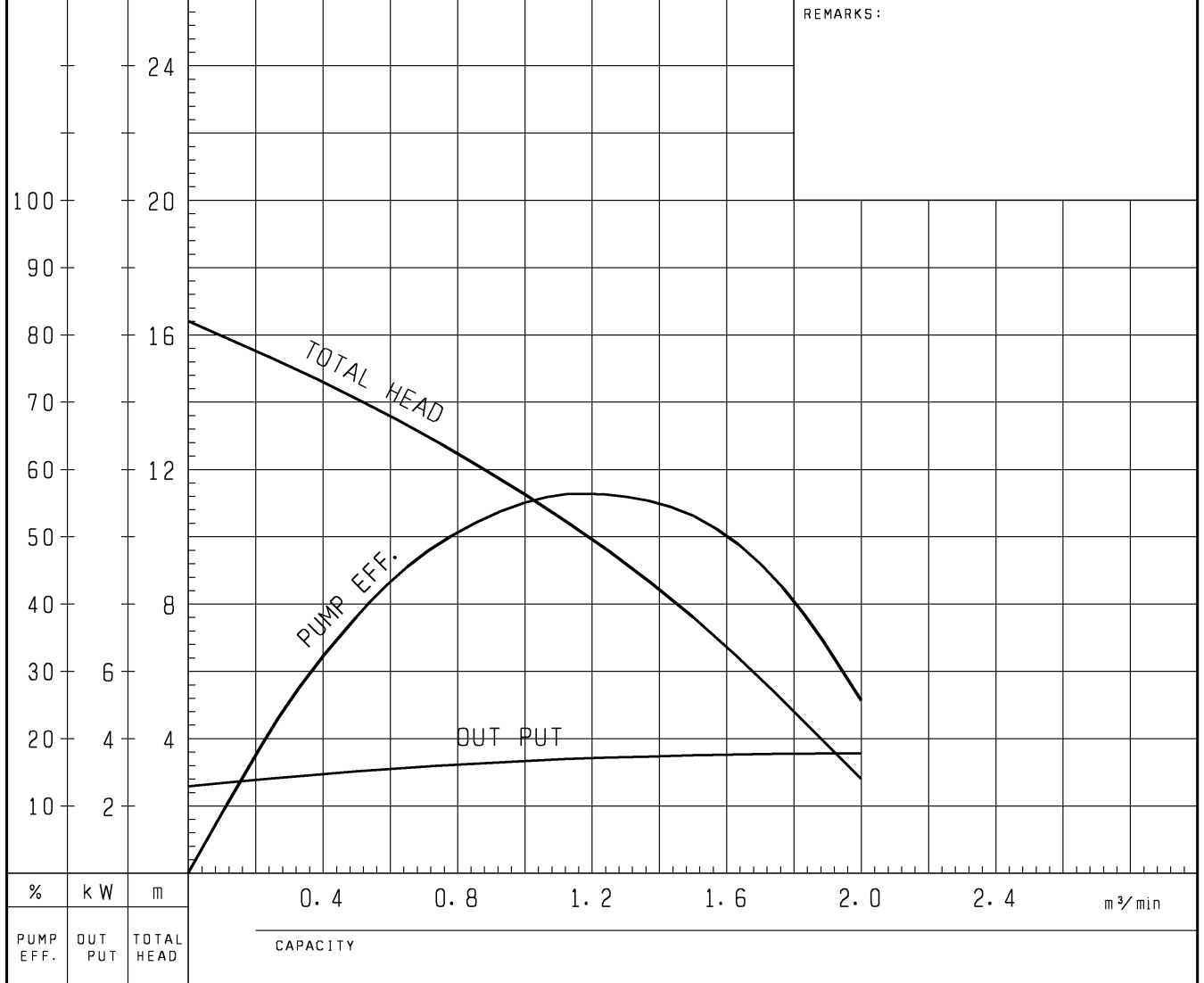

TSURUMI MFG. CO., LTD.

DIMENSION DRAWING		No.	No.
TYPE	Sewage Submersible Channel Impeller Pump (Automatic)	MODEL	100BA42.2 -51/61 100BA43.7 -51/61

MODEL	Approximate Weight (※)
100BA42.2-51/61	78kg
100BA43.7-51/61	94kg

※excluding cable

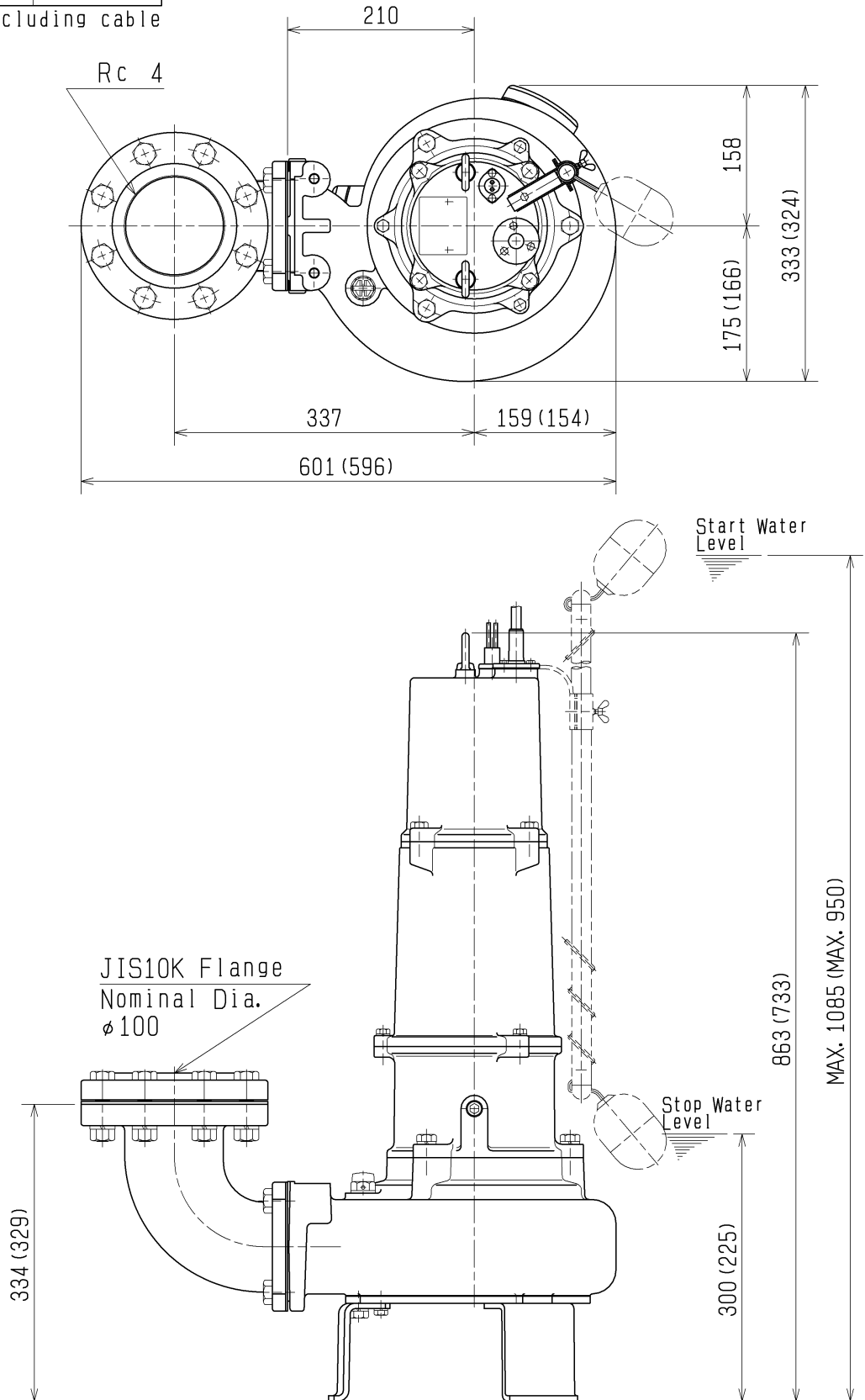

The Figure in ( ) shows the dimensions of 100BA42.2.

<b>SECTIONAL DRAWING</b>		No.	No.	A-19420-2
TYPE	Sewage Submersible Channel Impeller Pump (Automatic)	MODEL	100BA42.2 -51/61 100BA43.7 -51/61	

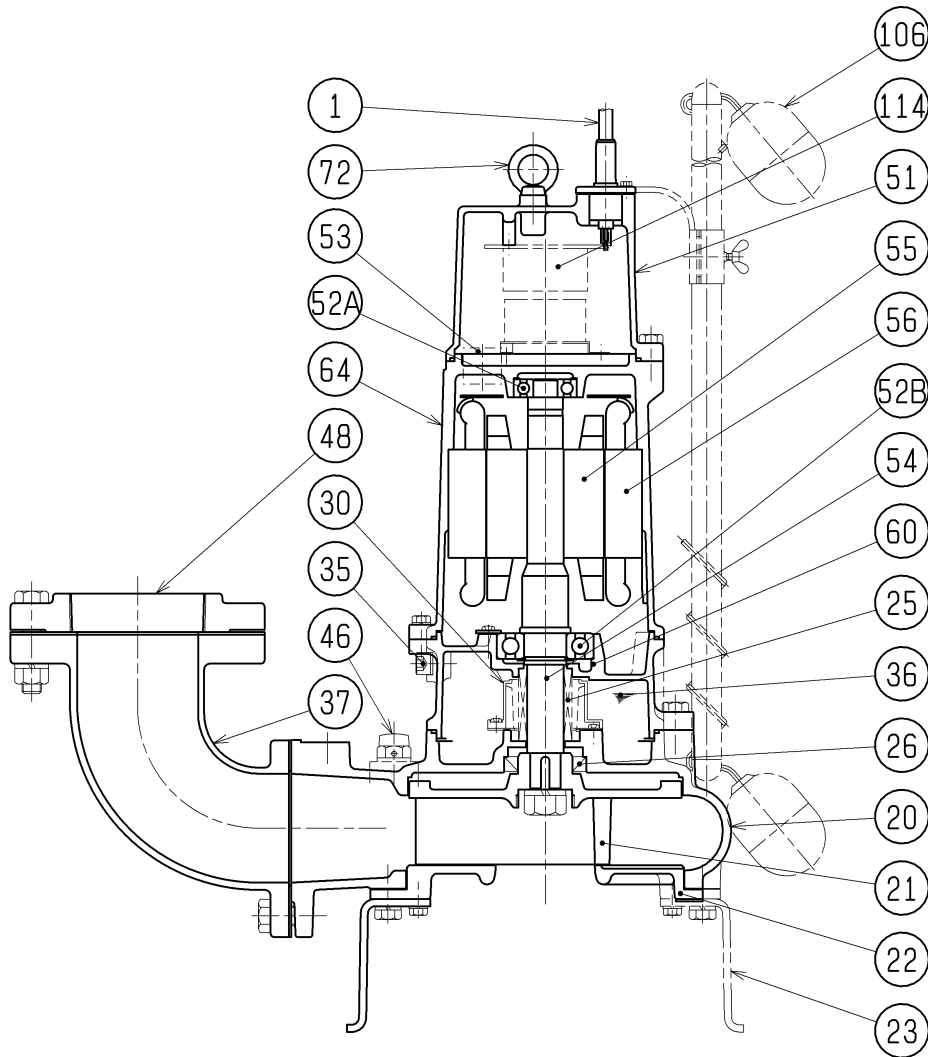

		2.2kW	3.7kW	REQ. SPECIFICATION			
※1	H-30A	H-35A					
※2	TC456812	TC507212					
※3	6307ZC3	6309ZC3	※4 the wetted part				
No.	DESCRIPTION	Q'TY	MATERIAL / NOTE	No.	DESCRIPTION	Q'TY	MATERIAL / NOTE
1	Cable	1	PVC Sheath	52A	Upper Bearing	1	6304ZC3
20	Pump Casing	1	Gray Iron Casting	52B	Lower Bearing	1	※3
21	Impeller	1	Gray Iron Casting	53	Motor Protector	1	
22	Suction Cover	1	Gray Iron Casting	54	Shaft	1	Stainless Steel 420J2(※4)
23	Stand	3	Steel Plate	55	Rotor	1	
25	Mechanical Seal	1	※1	56	Stator	1	
26	Oil Seal	1	※2	60	Bearing Housing	1	Gray Iron Casting
30	Oil Lifter	1	Plastic	64	Motor Frame	1	Gray Iron Casting
35	Oil Plug	1	Stainless Steel 304	72	Eye Bolt	2	Stainless Steel 304
36	Lubricant		Turbine Oil(ISO VG32)	106	Float	2	Plastic
37	Discharge Bend	1	Gray Iron Casting	114	Relay Unit	1	
46	Air Release Valve	1	Nylon				
48	Screwed Flange	1	Gray Iron Casting				
51	Head Cover	1	Gray Iron Casting				