

SPECIFICATIONS	Model	100BZ45.5							
		BZ-series 5.5kW, 3-phase							
<p>Type of Pump Submersible cast iron pump suitable for pumping sewage, wastewater, storm water, etc.</p> <p>Type of Fluid Sewage, wastewater, and water carrying solid matters</p> <p>Temperature: 0 to 40°C (High temperature model available on special request)</p> <p>Discharge Bore 100mm</p> <p>Motor Output 5.5kW</p> <p>Power Supply Three-phase</p> <p>Starting Method Direct on Line (Star-Delta available on special request)</p> <p>Motor Continuous-duty rated, dry-type induction motor</p> <p>Insulation Class: F Degree of Protection: IP68</p> <p>No. of Poles & Speed (Synchronous Speed) 4-pole, 1500/1800min⁻¹ (50/60Hz)</p> <p>Power Supply Voltages & Rated Currents</p> <table border="0"> <tr> <td>50Hz</td> <td>60Hz</td> </tr> <tr> <td>380V – 12.4A</td> <td>220V – 21.2A</td> </tr> <tr> <td>400V – 12.1A</td> <td>380V – 11.8A</td> </tr> <tr> <td>415V – 12.1A</td> <td>440V – 10.5A</td> </tr> </table> <p>Power Cable Sheath: Chloroprene rubber Standard Length: 10m 200 to 600V supply: 1 × 4 × 3.5mm², O.D. 14.1mm 1 × 2 × 1.25mm², O.D. 9.8mm</p> <p>Dry Weight (excluding cable) Free Standing Type: 149kg Guide Rail Fitting Type: 144kg</p>	50Hz	60Hz	380V – 12.4A	220V – 21.2A	400V – 12.1A	380V – 11.8A	415V – 12.1A	440V – 10.5A	<p>Impeller Shrouded two-channel impeller for solid-handling design, dynamically balanced</p> <p>Solids Passage 50Hz – ϕ80mm 60Hz – ϕ80mm</p> <p>Cable Entry with Anti-Wicking Block Watertight cable entry with strain-relief device. The anti-wicking block prevents water incursion due to capillary action should the power cable be damaged or the end submerged.</p> <p>Bearings Permanently lubricated, deep-groove, double-shielded C3 ball bearings</p> <p>Shaft 420 stainless steel</p> <p>Shaft Seal (Mechanical Seal) Furnished with a double-face mechanical seal located in oil chamber. Both upper and lower seal faces always run in a clean environment.</p> <p>Upper Seal Faces: Ceramic + Carbon Lower Seal Faces: SiC + SiC</p> <p>Oil Seal (Lip Seal) Used as a “Dust Seal”, it protects the mechanical seal from abrasive particles.</p> <p>OIL LIFTER (Patented) Equipped in oil chamber. It forcibly supplies lubricating oil to the mechanical seal and continues to supply the oil to the upper seal faces even if lubricant falls below the rated volume.</p> <p>Type of Lubricating Oil & Volume Turbine Oil (ISO VG32), 4300ml</p> <p>Motor Protection Device A miniature thermal protector is embedded in each winding of the motor. Should excessive heat builds up, the bimetal strip opens to cause the control panel to shut the power supply.</p>
50Hz	60Hz								
380V – 12.4A	220V – 21.2A								
400V – 12.1A	380V – 11.8A								
415V – 12.1A	440V – 10.5A								
<p>Optional Accessories</p> <p>Bend Set (Free Standing Type)</p> <ul style="list-style-type: none"> • Discharge Bend • JIS 10kg/cm² Screwed Flange <p>Stand Set (Free Standing Type)</p> <ul style="list-style-type: none"> • Stand <p>TOS/TS Set (Guide Rail Fitting Type)</p> <ul style="list-style-type: none"> • Duckfoot Bend • Guide Support • Guide Hook • Lifting Chain 5m (with Shackles) • JIS 10kg/cm² Screwed Flange (TOS Set only) <p>External Leakage Sensor</p>									
TSURUMI MANUFACTURING CO., LTD.									

NO.

A-19397-2

PUMP PERFORMANCE CURVES

 TYPE Sewage Submersible
 Channel Impeller Pump

 MODEL 100BZ45.5 -53
 TOS100BZ45.5 -53

FREQUENCY 50 Hz

CUSTOMER'S NAME

EQUIPMENT TITLE

NO.

	STANDARD SPECIFICATIONS	REQUIRED SPECIFICATIONS
DISCHARGE BORE	100 mm	mm
TOTAL HEAD	13 m	m
CAPACITY	1.0 m ³ /min	m ³ /min
MOTOR OUTPUT	5.5 kW	kW
PHASE × VOLTAGE	3 φ × V	φ × V
CURRENT	A	A
POLES / REVOLUTION	4 P / S. S. 1500 min ⁻¹	P / min ⁻¹
STARTING METHOD	DIRECT ON LINE	
INSULATION CLASS	F	

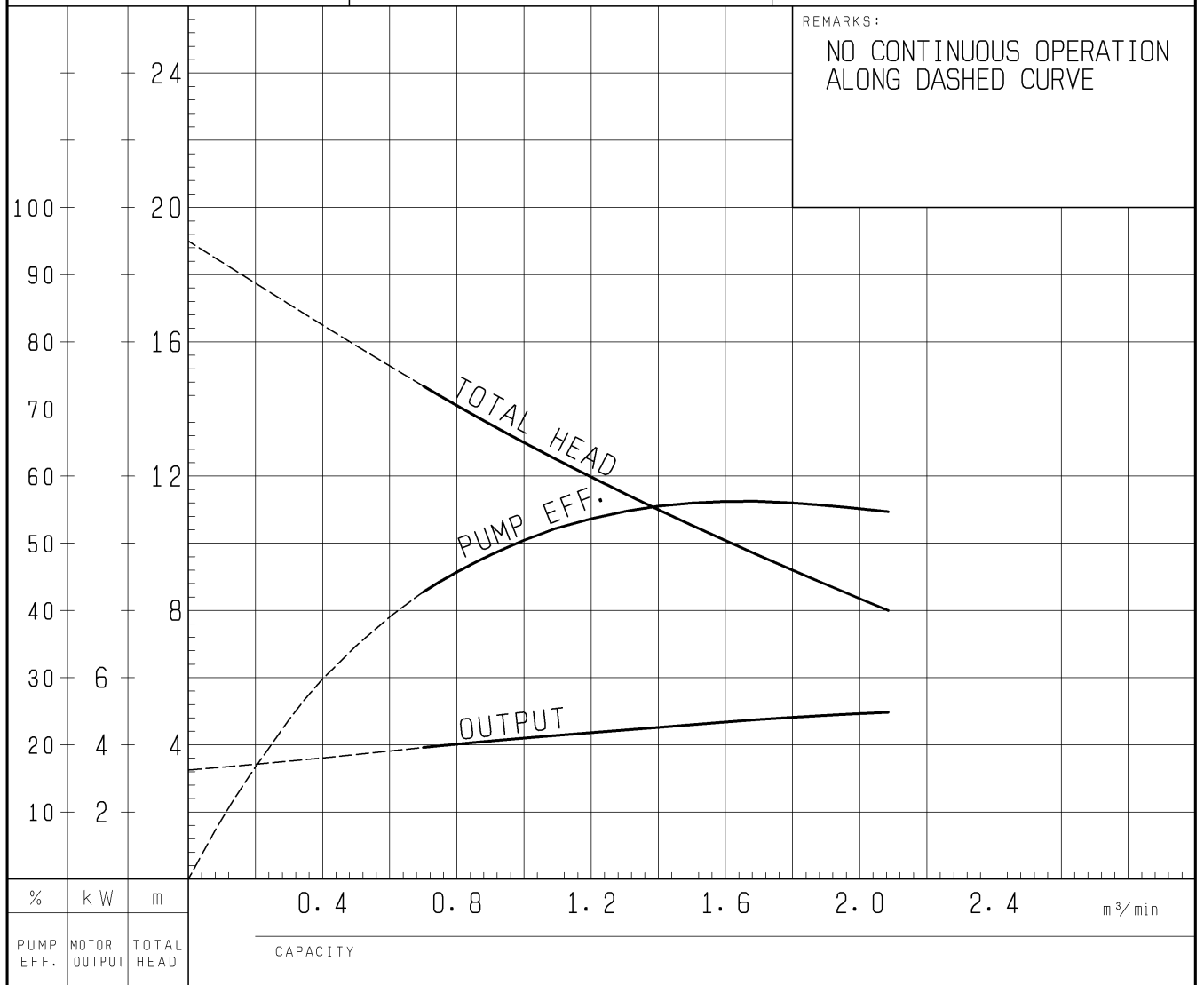

TSURUMI MFG. CO., LTD.

DIMENSION DRAWING		No.	No. A-19404-2
TYPE	Sewage Submersible Channel Impeller Pump	MODEL	100BZ45.5 -53/63 100BZ47.5 -53/63

MODEL	W1	H
100BZ45.5	790	924
100BZ47.5	820	945

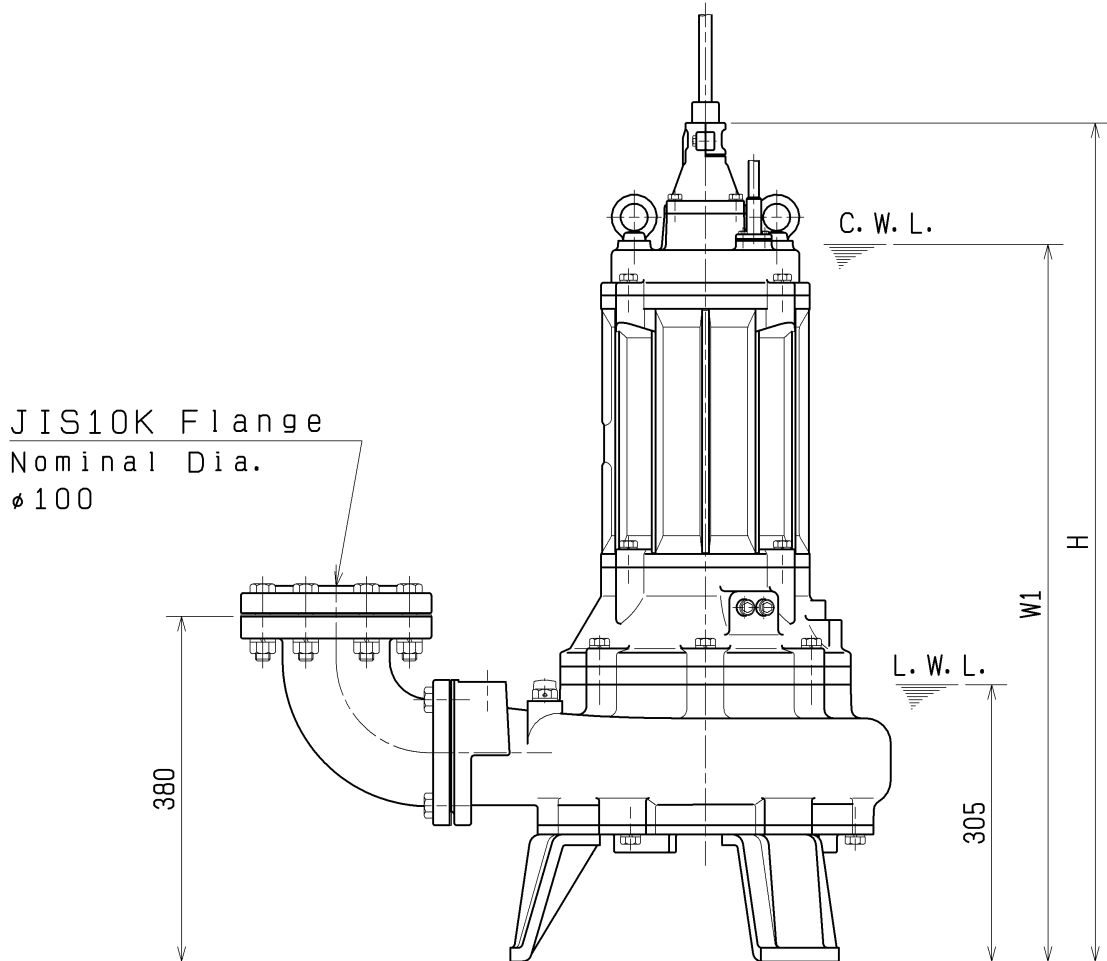
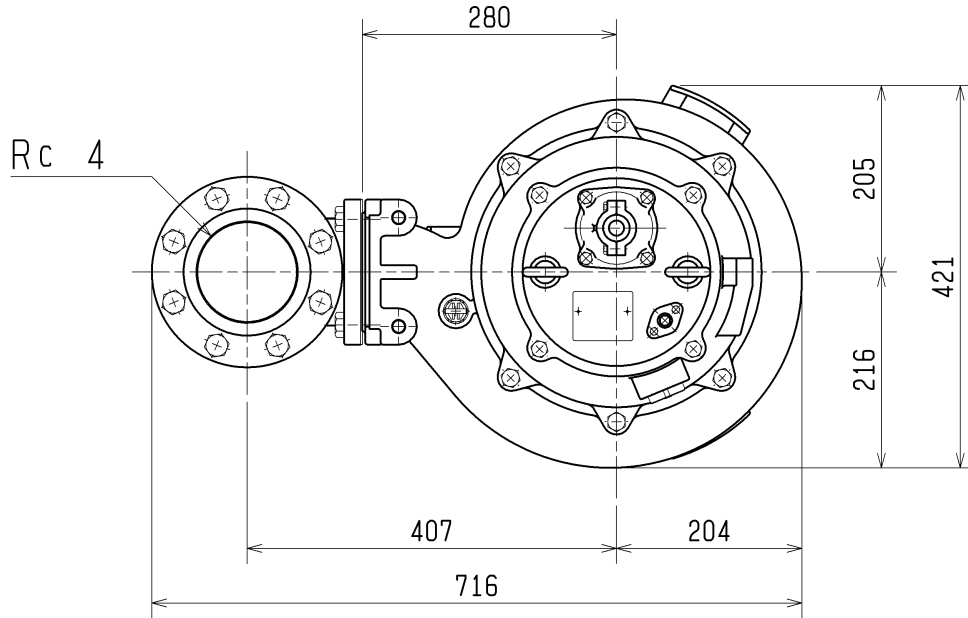

C.W.L. :Continuous running Water Level
L.W.L. :Lowest running Water Level

SECTIONAL DRAWING		No.	No. A-19406-1
TYPE	Sewage Submersible Channel Impeller Pump	MODEL	100BZ45.5 -53/63 100BZ47.5 -53/63

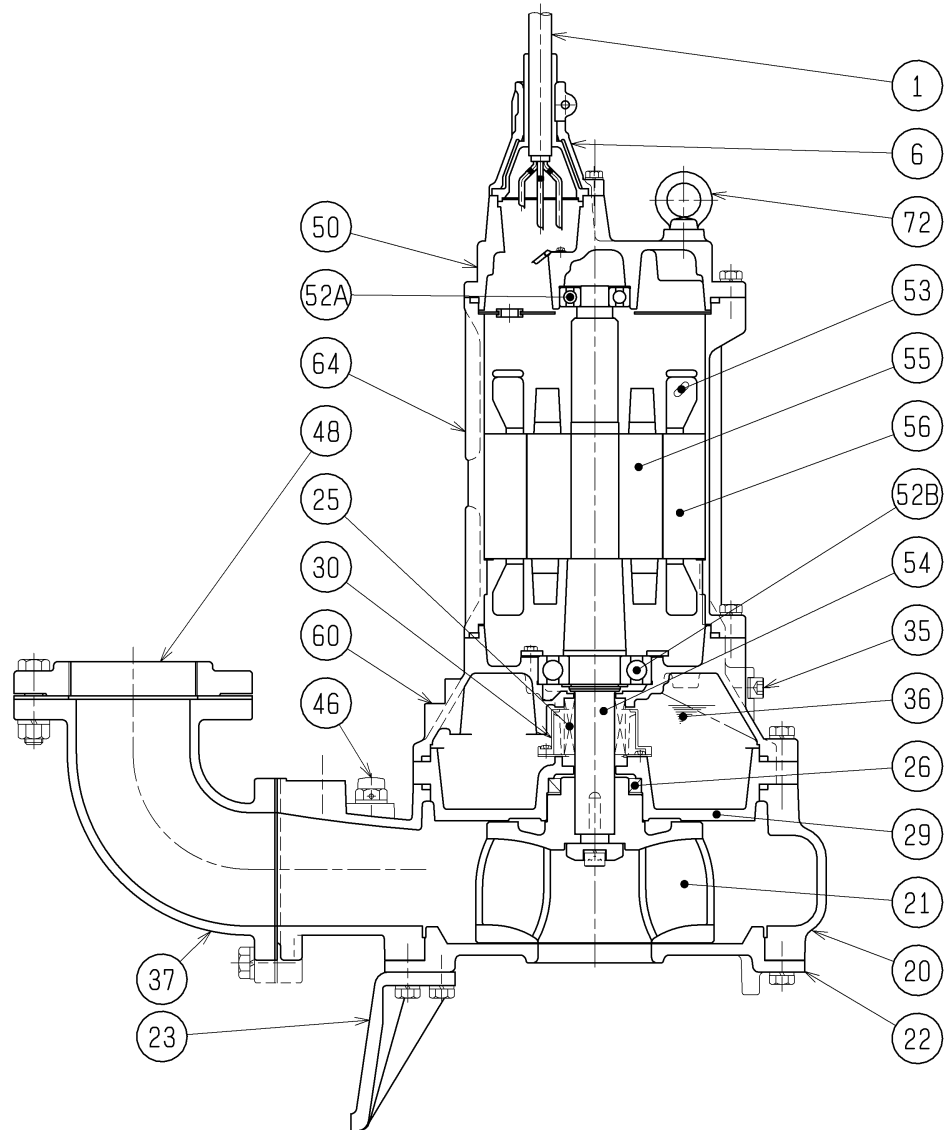

REQ. SPECIFICATION

※1	
5.5kW	6305ZC3
7.5kW	6306ZC3

No.	DESCRIPTION	Q'TY	MATERIAL / NOTE	No.	DESCRIPTION	Q'TY	MATERIAL / NOTE
1	Cable	2	Chloroprene Sheath	48	Screwed Flange	1	Gray Iron Casting
6	Stuffing Box	1	Gray Iron Casting	50	Motor Bracket	1	Gray Iron Casting
20	Pump Casing	1	Gray Iron Casting	52A	Upper Bearing	1	※1
21	Impeller	1	Gray Iron Casting	52B	Lower Bearing	1	6309ZC3
22	Suction Cover	1	Gray Iron Casting	53	Motor Protector	3	
23	Stand	3	Gray Iron Casting	54	Shaft	1	Stainless Steel 420J2
25	Mechanical Seal	1	H-35A	55	Rotor	1	
26	Oil Seal	1	TC608212	56	Stator	1	
29	Oil Casing	1	Gray Iron Casting	60	Bearing Housing	1	Gray Iron Casting
30	Oil Lifter	1	Plastic	64	Motor Frame	1	Gray Iron Casting
35	Oil Plug	2	Stainless Steel 304	72	Eyebolt	2	Structure Steel
36	Lubricant		Turbine Oil (ISO VG32)				
37	Discharge Bend	1	Gray Iron Casting				
46	Air Release Valve	1	Nylon				