

SPECIFICATIONS	Model	PU-series							
	40PU2.25	0.25kW, 3-phase							
<p>Type of Pump Submersible vortex pump made of 304 stainless steel and resin suitable for pumping sewage, wastewater, storm water, etc.</p> <p>Type of Fluid Sewage, wastewater, and water carrying solid matters</p> <p>Temperature: 0 to 40°C</p> <p>Discharge Bore 40mm</p> <p>Motor Output 0.25kW</p> <p>Power Supply Three-phase</p> <p>Starting Method Direct on Line</p> <p>Motor Continuous-duty rated, dry-type induction motor</p> <p>Insulation Class: E Degree of Protection: IP68</p> <p>No. of Poles & Speed (Synchronous Speed) 2-pole, 3000/3600min⁻¹ (50/60Hz)</p> <p>Power Supply Voltages & Rated Currents</p> <table border="0"> <tr> <td>50Hz</td> <td>60Hz</td> </tr> <tr> <td>380V – 0.9A</td> <td>220V – 1.6A</td> </tr> <tr> <td>400V – 0.9A</td> <td>380V – 0.9A</td> </tr> <tr> <td>415V – 1.0A</td> <td>440V – 0.8A</td> </tr> </table> <p>Power Cable Sheath: PVC Standard Length: 6m 200 to 600V supply: 1 × 4 × 1.25mm², O.D. 11.1mm</p> <p>Dry Weight (excluding cable) Standard Model: 6.1kg Auto & Auto-Alternation Model: 6.8kg</p>	50Hz	60Hz	380V – 0.9A	220V – 1.6A	400V – 0.9A	380V – 0.9A	415V – 1.0A	440V – 0.8A	<p>Impeller Vortex impeller made of glass-fiber reinforced PPO</p> <p>Solids Passage 50Hz – ϕ35mm 60Hz – ϕ35mm</p> <p>Cable Entry with Anti-Wicking Block Watertight cable entry with strain-relief device. The anti-wicking block prevents water incursion due to capillary action should the power cable be damaged or the end submerged.</p> <p>Bearings Permanently lubricated, deep-groove, double-shielded C3 ball bearings</p> <p>Shaft 304 stainless steel</p> <p>Shaft Seal (Mechanical Seal) Furnished with a double-face mechanical seal located in oil chamber. Both upper and lower seal faces always run in a clean environment.</p> <p>Upper Seal Faces: Ceramic + Carbon Lower Seal Faces: SiC + Ceramic</p> <p>OIL LIFTER (Patented) Equipped in oil chamber. It forcibly supplies lubricating oil to the mechanical seal and continues to supply the oil to the upper seal faces even if lubricant falls below the rated volume.</p> <p>Type of Lubricating Oil & Volume Liquid Paraffin (ISO VG32), 240ml</p> <p>Motor Protection Device A circle thermal protector built in the motor housing. Directly cuts the motor circuit if excessive heat builds up or an overcurrent condition occurs in the motor.</p>
50Hz	60Hz								
380V – 0.9A	220V – 1.6A								
400V – 0.9A	380V – 0.9A								
415V – 1.0A	440V – 0.8A								
<p>Optional Accessories</p> <p>TOK Set (Guide Rail Fitting Type)</p> <ul style="list-style-type: none"> • Duckfoot Bend • Guide Support • Guide Hook • Lifting Chain 4m (with Shackles) 									
TSURUMI MANUFACTURING CO., LTD.									

NO.

A-09945-1

PUMP PERFORMANCE CURVES

TYPE Sewage
Submersible Vortex Pump

MODEL 40PU2.25 -52, 40PUA2.25 -52
40PUW2.25 -52, 50PU2.25 -52

FREQUENCY
50 Hz

CUSTOMER'S NAME

EQUIPMENT TITLE

NO.

	STANDARD SPECIFICATIONS	REQUIRED SPECIFICATIONS
DISCHARGE BORE	※ 40/50 mm	mm
TOTAL HEAD	4.0 m	m
CAPACITY	0.14 m ³ /min	m ³ /min
MOTOR OUTPUT	0.25 kW	kW
PHASE × VOLTAGE	3 φ × V	φ × V
CURRENT	A	A
POLES / REVOLUTION	2 P / S. S. 3000 min ⁻¹	P / min ⁻¹
STARTING METHOD	DIRECT ON LINE	
INSULATION CLASS	E	

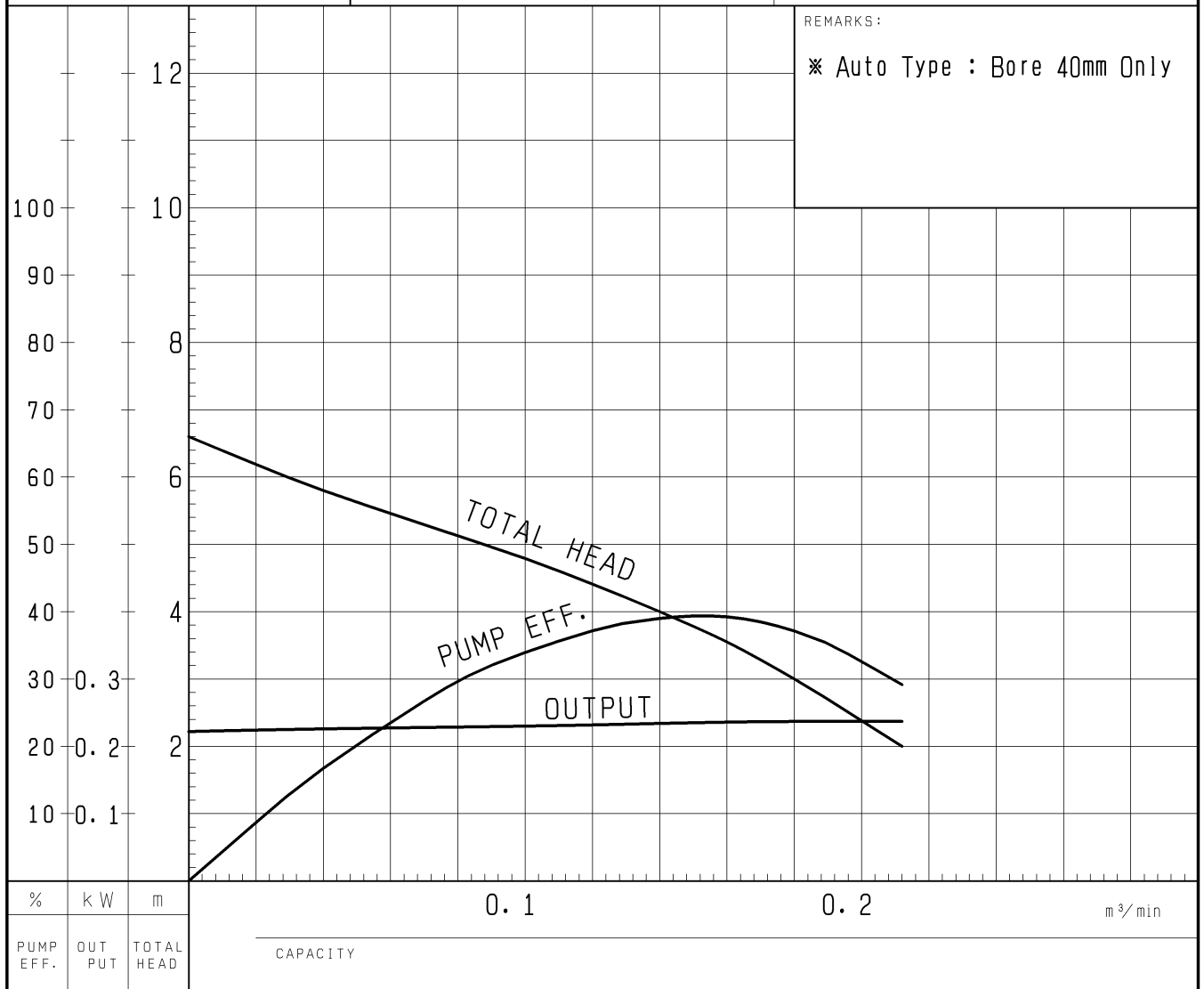

TSURUMI MFG. CO., LTD.

DIMENSION DRAWING		No.	No. A-09978-2
TYPE Sewage Submersible Vortex Pump (Auto-Alternation)		MODEL 40PUW2.25 -52/62	

Approximate Weight (※)
6.8kg
※excluding cable

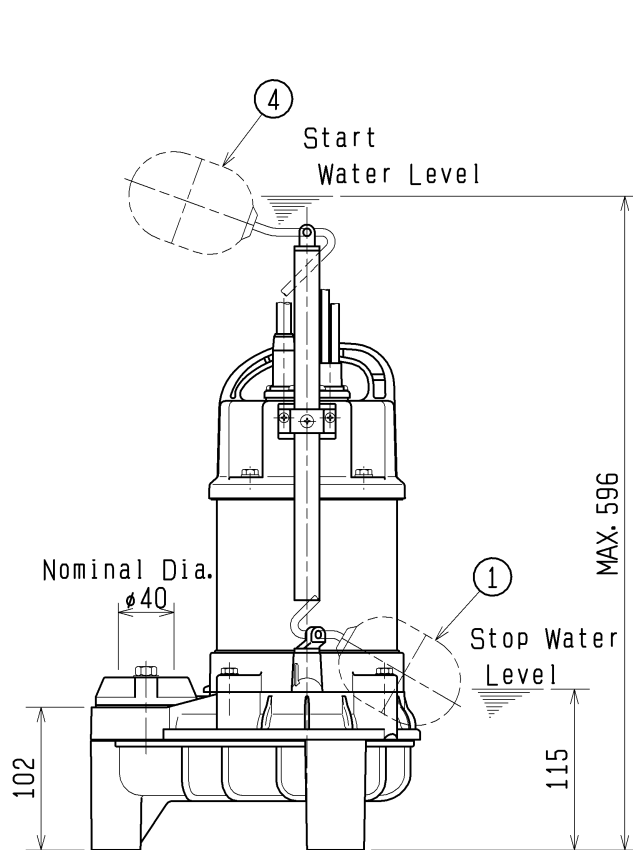
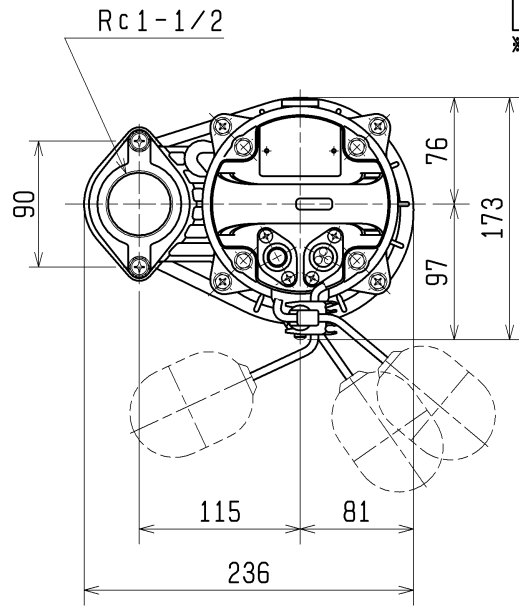
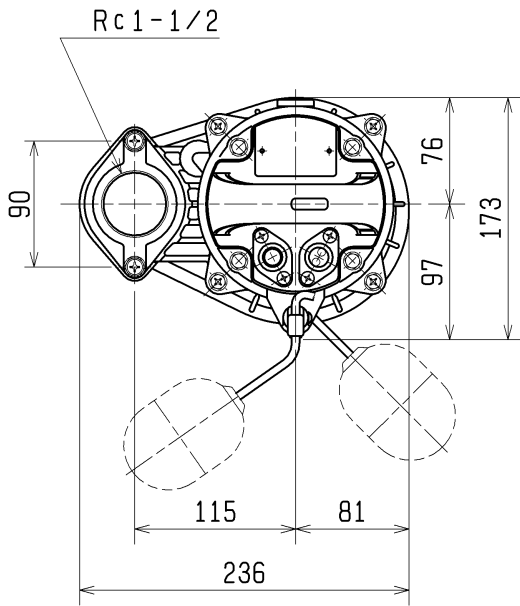

No. 1 PUMP

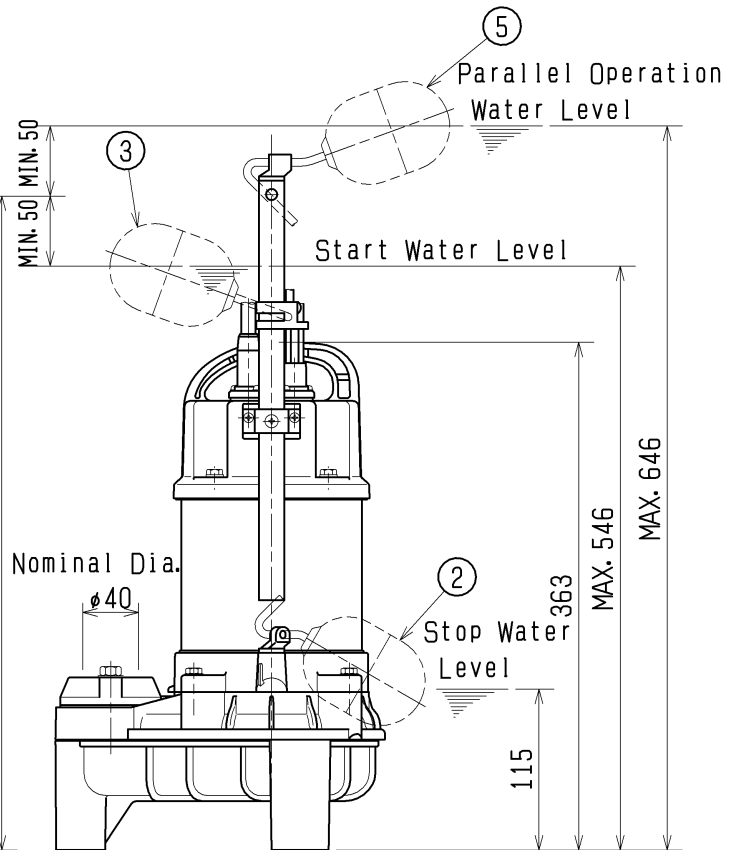

No. 2 PUMP

No.	Item	Color	No.	Item	Color
①	No. 1 Pump Stop Float	Red	④	No. 1 Pump Start Float	Yellow
②	No. 2 Pump Stop Float	Red	⑤	No. 1 Pump No. 2 Pump Parallel Operation Float	Green
③	No. 2 Pump Alternate Start Float	Yellow			

SECTIONAL DRAWING		No.	No. A-10024-3
TYPE Sewage Submersible Vortex Pump (Auto-Alternation)		MODEL 40PUW2.25 -52/62, 50PUW2.4 -52/62 50PUW2.75 -52/62	

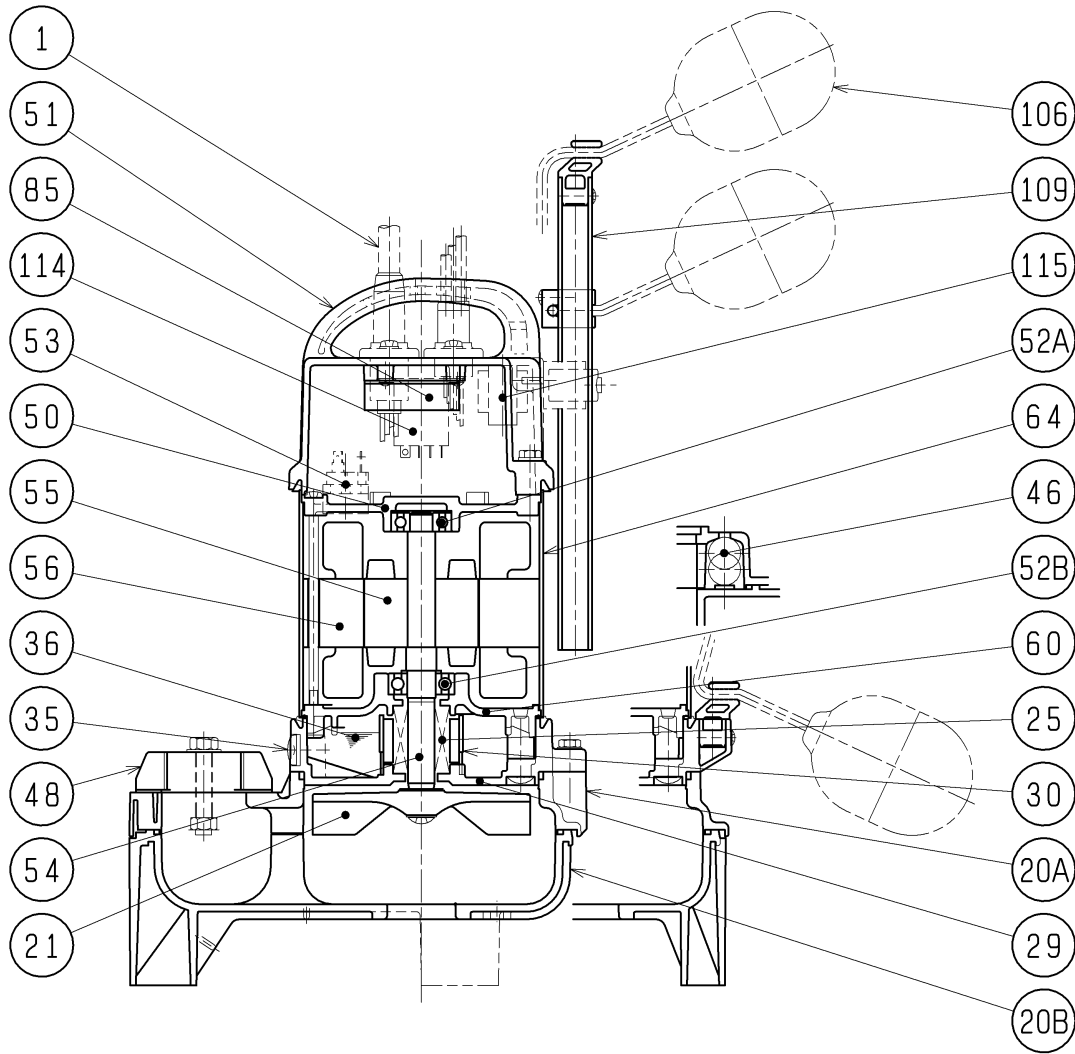

REQ. SPECIFICATION

* Upper and lower blocks form a one-piece casing.

No.	DESCRIPTION	QTY	MATERIAL / NOTE	No.	DESCRIPTION	QTY	MATERIAL / NOTE
1	Cabtyre Cable	1	PVC Sheath	53	Motor Protector	1	
20A	Upper Pump Casing	*1	Plastic W/GF	54	Shaft	1	Stainless Steel 304
20B	Lower Pump Casing	1	Plastic	55	Rotor	1	
21	Impeller	1	Plastic W/GF	56	Stator	1	
25	Mechanical Seal	1	W-14HC	60	Bearing Housing	1	Aluminium Die Casting
29	Oil Casing	1	Plastic W/GF	64	Motor Frame	1	Stainless Steel 304
30	Oil Lifter	1	Plastic	85	Relay Unit	1	
35	Oil Plug	1	Stainless Steel 304	106	Float	3	Plastic
36	Lubricant		Liquid Paraffin (ISO VG32)	109	Float Support Pipe	1	Plastic
46	Air Release Valve	1	Glass Ball	114	Power Relay	1	
48	Screwed Flange	1	Plastic W/GF	115	Transfolmer	1	
50	Motor Bracket	1	Aluminium Die Casting				
51	Head Cover	1	Plastic W/GF				
52A	Upper Bearing	1	6201ZZC3				
52B	Lower Bearing	1	0.25/0.4kW:6202ZZC3				
			0.75kW :6302ZZC3				